

Kompresor™ EXP Series 630 MM Filter Press

The Kompresor™ Series construction:

- The **Kompresor™** filter press head, tail and following plate sections are fabricated from substantial 3" solid-flat plate steel that is sand blasted and machined to meet strict design tolerances. The frame "rails" are constructed from a section of solid-cold rolled steel that is a beefy 1.0 in. thick and 6.0 in. wide tapped and bolted with 2 -.50 in. high strength (#8) steel bolts, pinned and welded for maximum strength and safety. As an extra measure, the **Kompresor™** frame is phosphate treated and painted with a high quality 2-part epoxy coating that is applied 7-10 mils thick. To top it off, the rails are fitted with (.061) 316 SS rail cap to resist corrosion and extend service life.

Technical Specifications

Model	6300-25-EXP
Volume (ft ³)	8.0 – 12.0
Plate Size (MM)	630
Plates	24-36
Max. Pressure (psi)	100
Spacer (in.)	28.2
Height (in.)	54.0
Width (in.)	28.5
Rail Length (in.)	112.93
Total Length (in.)	140.93

- The space saving "flip-up" air-actuated press hydraulic cylinder and hand operated control valve enable smooth open-close transitions as well as a "rock solid" plate compression cycle.
- The **Kompresor™** 630 MM plates are constructed from 2.44" thick corrosion resistant molded polypropylene to eliminate warping and EPDM gasket and O-ring material for leak free operation.
- The filter cloths are made from polypropylene fabric with a satin finish that allows quick solids release and easy clean-up.
- The feed/discharge manifold is manufactured with heavy SCH 80 PVC and high quality PVC automatic or manual valves.
- The optional Clean-in-place (CIP) system is available to keep the **Kompresor™** filter press running at optimal performance with minimal downtime.

"The Clear Choice for Industrial Wastewater Treatment"

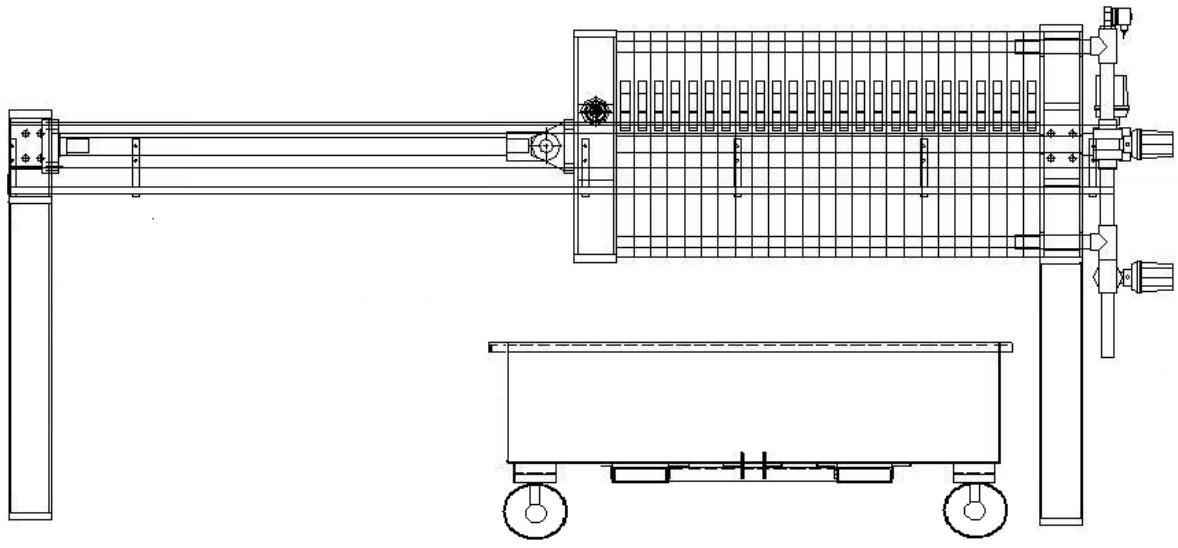

“The Clear Choice for Industrial Wastewater Treatment”